

CIRCUIT DIAGRAM

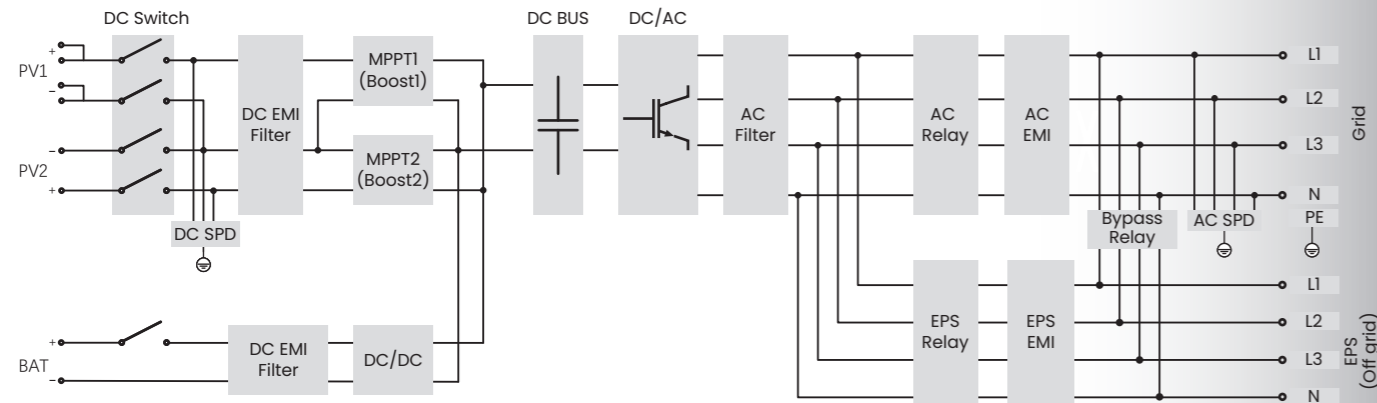

X3-Hybrid G4

5.0kW/6.0kW/8.0kW/10.0kW/12.0kW/15.0kW



Features

Three-phase Hybrid inverter



Intelligent

- 150% EPS overload output for 10s
- Switchover time <10ms
- Quick configuration with U-disk
- Lithium-ion & Lead-acid battery compatible
- CT compatible, loads respond within 0.3s
- Intelligent loads management (e.g., Heat pump)
- On & Off-grid parallel function, up to 150kW
- 5 work modes, 2 charging periods available
- VPP ready, ancillary service in power market
- Three-phase unbalanced output Maximum 5kW output power on single phase at most
- Super-backup ready, EPS operation without batteries



Safe

- IP65 protection level
- Integrated SPD



High-efficient

- 200% PV oversized and up to 110% AC overload output
- Higher efficiency on charging and discharging, up to 97.5%
- Built-in shadow tracking function



Economic

- 16A DC single string input current, support high power solar panel
- Up to 150% PV input
- Store the surplus energy from PV to battery
- Low start output voltage makes inverter longer working time
- Less energy loss on battery to inverter
- Dual peak limit value, flexible optimization of electricity bills



POWERING A GREEN FUTURE



www.solaxpower.com

Global: +86 571-56260008
PL: +48 662 430 292

AU: +61 1300 476 529
DE: +49 (0) 6142 4091 664

UK: +44 2476 586998
NED: +31 (0) 8527 37932

info@solaxpower.com
service@solaxpower.com

V3.0 Information may be subject to modify without notice.
650.00010.00



X3-HYBRID G4 (THREE PHASE)

X3-HYBRID-5.0-D X3-HYBRID-6.0-D X3-HYBRID-8.0-D X3-HYBRID-10.0-D X3-HYBRID-12.0-D X3-HYBRID-15.0-D

DC INPUT	X3-HYBRID-5.0-D	X3-HYBRID-6.0-D	X3-HYBRID-8.0-D	X3-HYBRID-10.0-D	X3-HYBRID-12.0-D	X3-HYBRID-15.0-D
Max. PV array power [Wp]	10000	12000	16000	20000	24000	30000
Max. PV input voltage [V]	1000	1000	1000	1000	1000	1000
Start output voltage [V]	200	200	200	200	200	200
Nominal input voltage [V]	640	640	640	640	640	640
MPP voltage range [V]	180~950	180~950	180~950	180~950	180~950	180~950
No. of MPP trackers / Strings per MPP tracker	2 (1/1)	2 (1/1)	2 (2/1)	2 (2/1)	2 (2/1)	2 (2/1)
Max. input current (input PV1 / input PV2) [A]	16 / 16	16 / 16	28 / 16	28 / 16	28 / 16	28 / 16
Max. short circuit current (input PV1 / input PV2) [A]	20 / 20	20 / 20	35 / 20	35 / 20	35 / 20	35 / 20

AC INPUT & OUTPUT						
Nominal AC output power [W]	5000	6000	8000	10000	12000	15000
Max. AC output apparent power [VA]	5500	6600	8800	11000	13200	15000
Max. AC output current [A]	8.1	9.7	12.9	16.1	19.3	24.1
Max. AC input apparent power [VA]	10000	12000	16000	20000	20000	20000
Max. AC input current [A]	16.1	19.3	25.8	32.0	32.0	32.0
Nominal AC voltage [V]	415 / 240; 400 / 230; 380 / 220					
Nominal grid frequency [Hz]	50 / 60					
Displacement power factor	0.8 leading ~ 0.8 lagging					
THDi (rated power) [%]	< 3					

BATTERY DATA						
Battery type	Lithium-ion battery / Lead-acid Battery					
Battery voltage range [V]	120 ~ 800 ^①					
Max. continuous charge / discharge current [A]	30					

EPS(OFF-GRID OR BACK-UP) OUTPUT (WITH BATTERY)						
Nominal output power [W]	5000	6000	8000	10000	12000	15000
Peak apparent power [VA]	12000, 10s	12000, 10s	18000, 10s	18000, 10s	22500, 10s	22500, 10s
Max. continuous current [A]	7.2	8.7	11.6	14.5	17.5	21.8
Nominal voltage [V]; Frequency [Hz]	400 / 230; 50 / 60					
Switch time [ms]	< 10					
Parallel operation	YES					

SYSTEM DATA						
Max. efficiency [%]	98.0					
Euro. efficiency [%]	97.7					
Battery charge / discharge efficiency [%] ^②	98.5 / 97.5					
Degree of protection	IP65					
Operating temperature range [°C]	-35 ~ +60 (Derating above +45)					
Max. operation altitude [m]	< 3000					
Relative humidity [%]	0 ~ 100					
Typical noise emission [dB]	< 35			< 45		
Storage temperature [°C]	-40 ~ +70					
Dimensions (WxHxD) [mm]	503 x 503 x 199					
Net weight [kg]	30±1					
Cooling concept	Nature cooling			Smart cooling		
Communication interfaces	CT / Meter (optional), External control RS485, Pocket WiFi (Optional: Pocket Lan / 4G), DRM, USB Upgrade, NTC (optional)					

POWER CONSUMPTION						
Internal consumption (night) [W]	< 40W for standby, < 5W for idle					

STANDARD						
Safety	EN/IEC62109-1 / -2					
EMC	EN61000-6-1 / 2 / 3 / 4; EN61000-3-2 / 3 / 11 / 12					
Certification	VDE4105, G99, G98, AS4777, EN50549, CEI 0-21, IEC61727, PEA / MEA, NRS-097-2-1, RD1699, TOR					

X3-HYBRID-5.0-D X3-HYBRID-6.0-D X3-HYBRID-8.0-D X3-HYBRID-10.0-D X3-HYBRID-12.0-D X3-HYBRID-15.0-D

PROTECTION

Anti-Islanding protection	Yes
DC reverse polarity protection	Yes
Insulation monitoring	Yes
Residual current monitoring	Yes
AC overcurrent protection	Yes
AC short-circuit protection	Yes
AC overvoltage protection	Yes
AFCI	OPT
surge protection	Type II, DC and AC

①: Compatible with a minimum of 3 units of HS25/HS36 batteries, but if the total voltage of the 3 batteries is less than 127V and there is no PV input, the system will not be able to startup
 ②: PV to BAT Max. efficiency 98.5%, BAT to AC Max. efficiency 97.5%.

EFFICIENCY CURVE

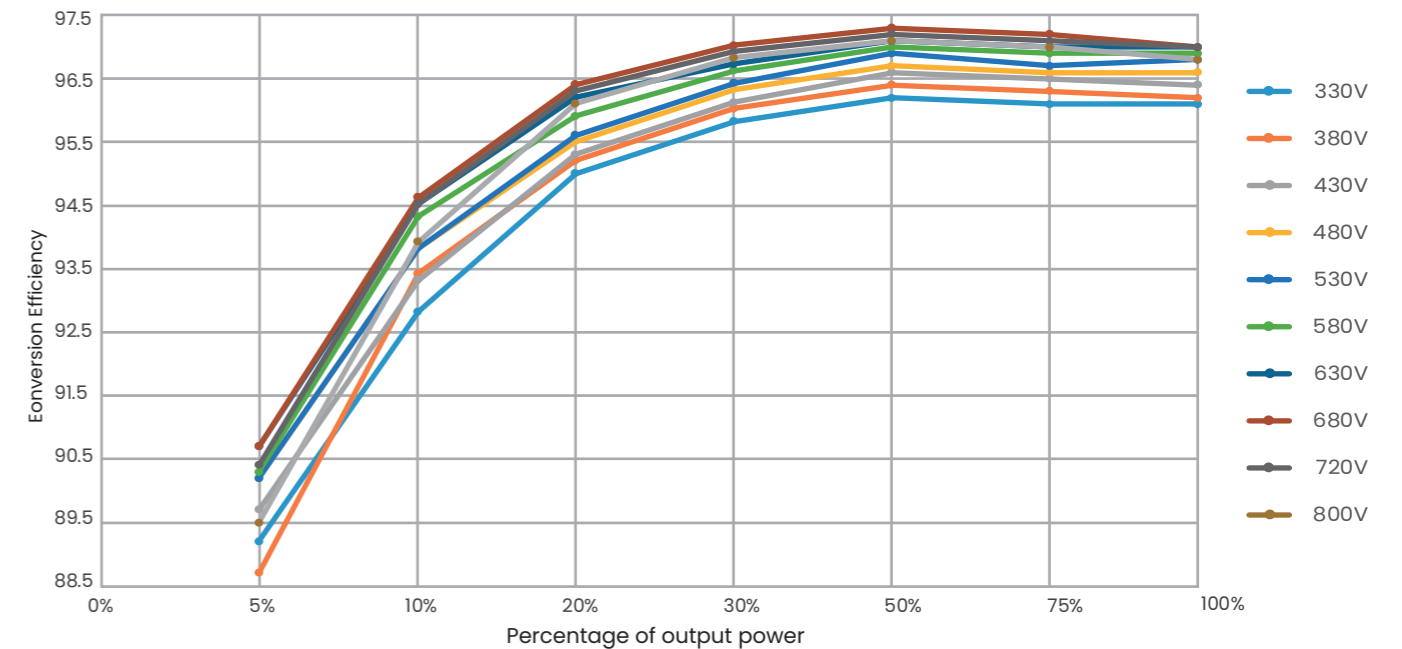

DERATING CURVE

